

Parts List											
ITEM	QTY	PART NUMBER	DESCRIPTION	MAT	TYP	H	W	L	T	OD	MASS
1	3	3018T17	2200 LB EYEBOLT								0.519 lbmass
2	47	90566A029	1/4"-20 NYLON INSERT LOCK NUT								0.008 lbmass
3	47	91083A029	1/4" WASHER		WASHER						0.004 lbmass
4	12	91083A033	1/2" WASHER		WASHER						0.018 lbmass
5	6	91251A730	1/2"-13 X 4 1/2" LG SOCKET HEAD CAP SCREW								0.305 lbmass
6	47	91253A560	1/4"-20 X 3" LG FLAT HEAD CAP SCREW								0.045 lbmass
7	1	QS-01-01	QUARTER SURROUND FRAME 1	STEEL	WELDMNT						427.203 lbmass
8	1	QS-01-02	FLOOR PANEL	6061-T651 ALUMINUM	PLATE	0.25	60	128			120.032 lbmass
9	1	QS-01-03	FLOOR PANEL	6061-T651 ALUMINUM	PLATE	0.25	41.223	60			41.812 lbmass
10	6	QS-01-06	LOCATING LEVELING FOOT		ASSEMBLY						3.863 lbmass

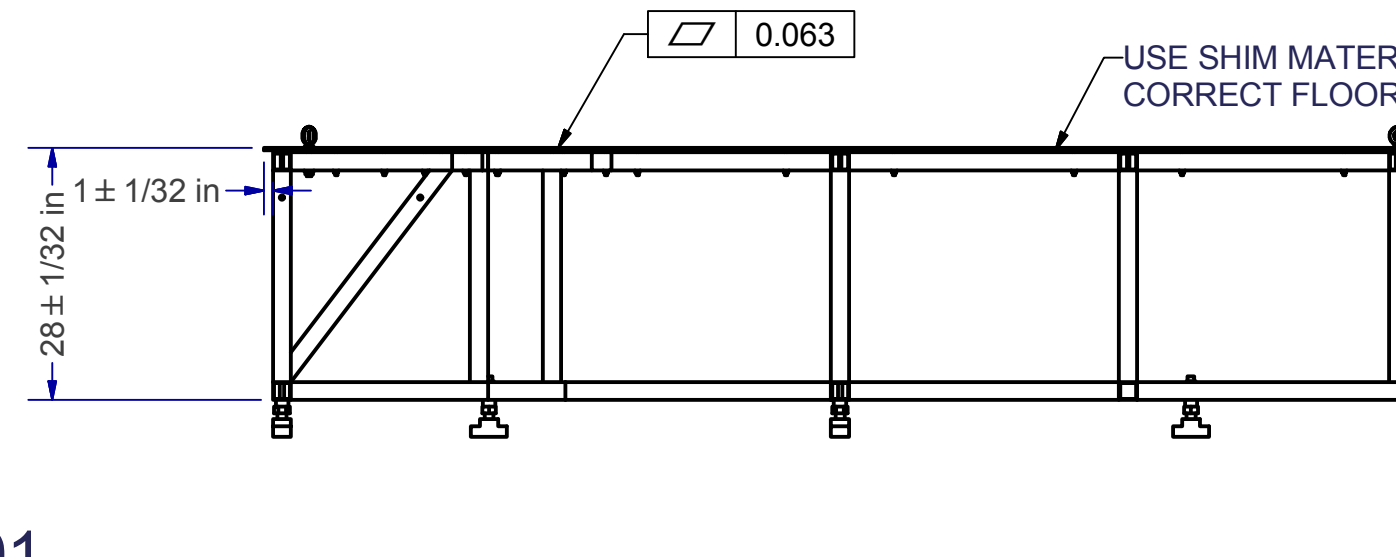
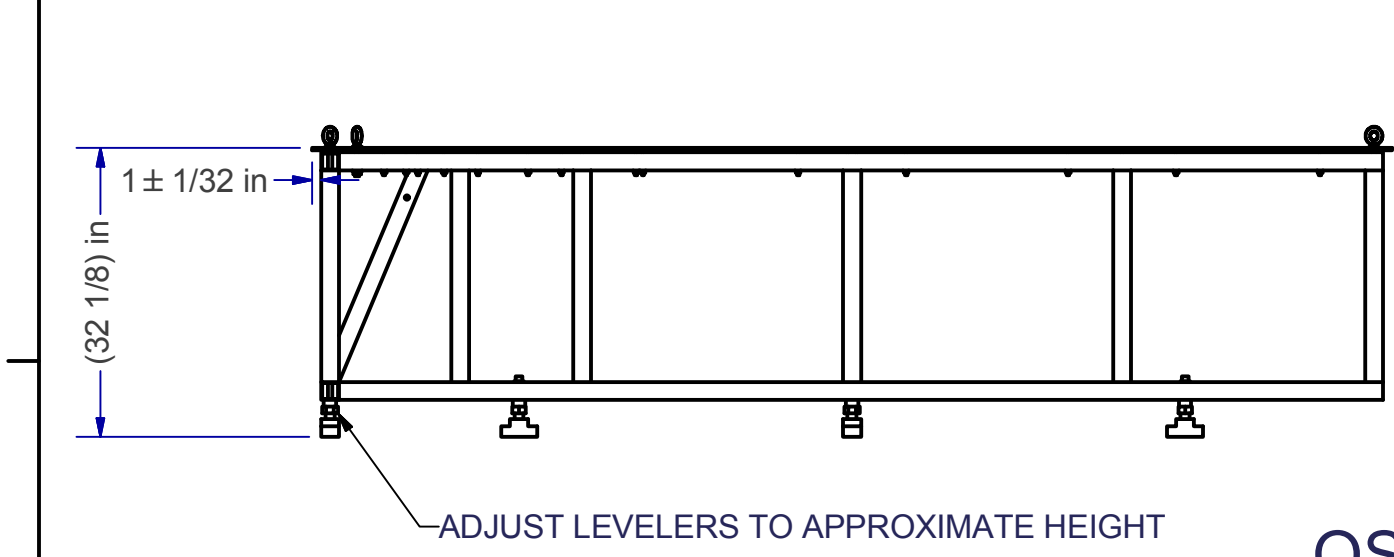
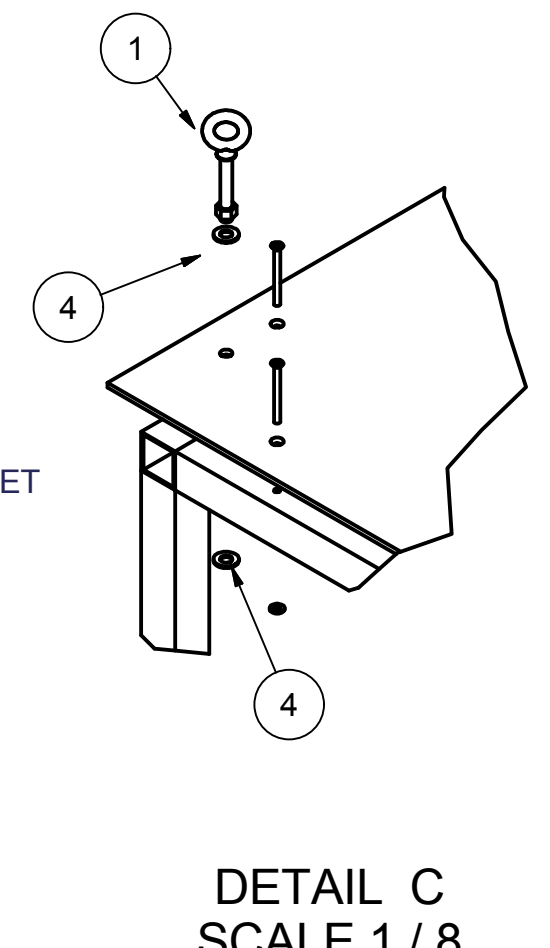
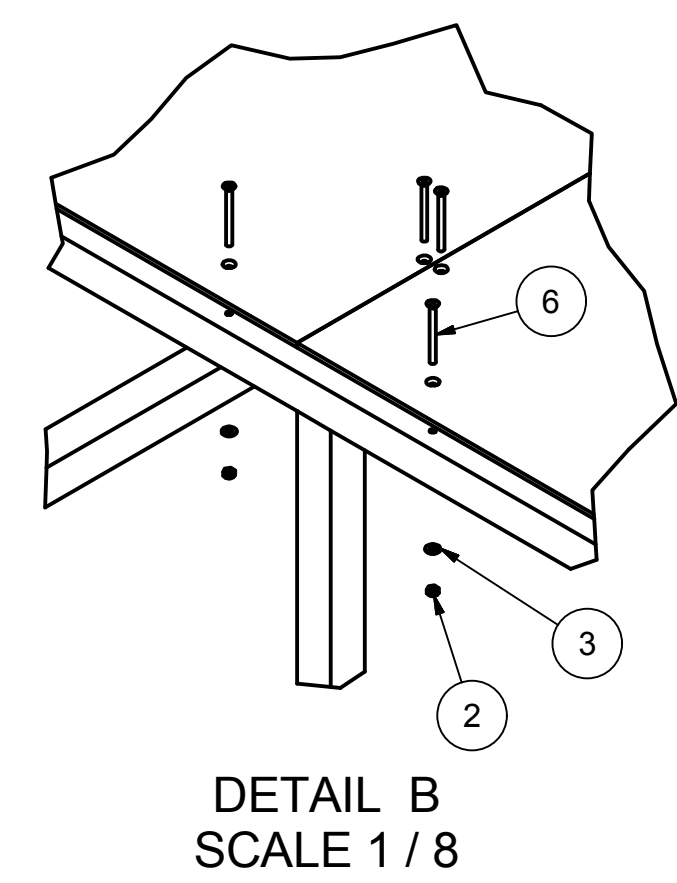
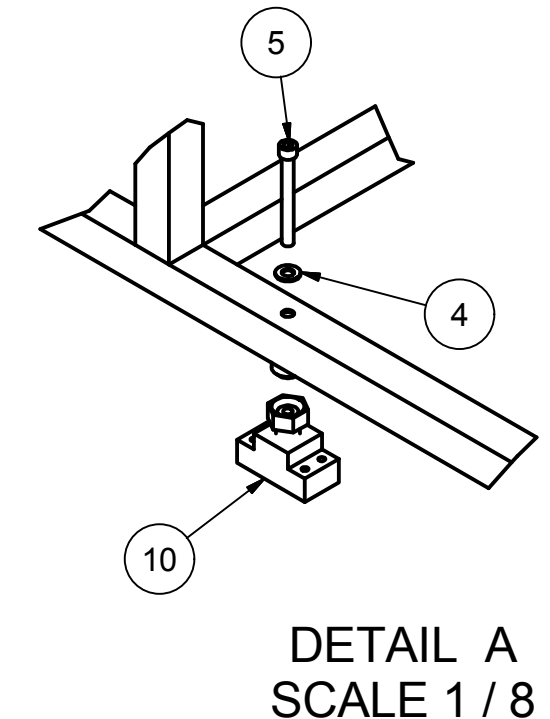
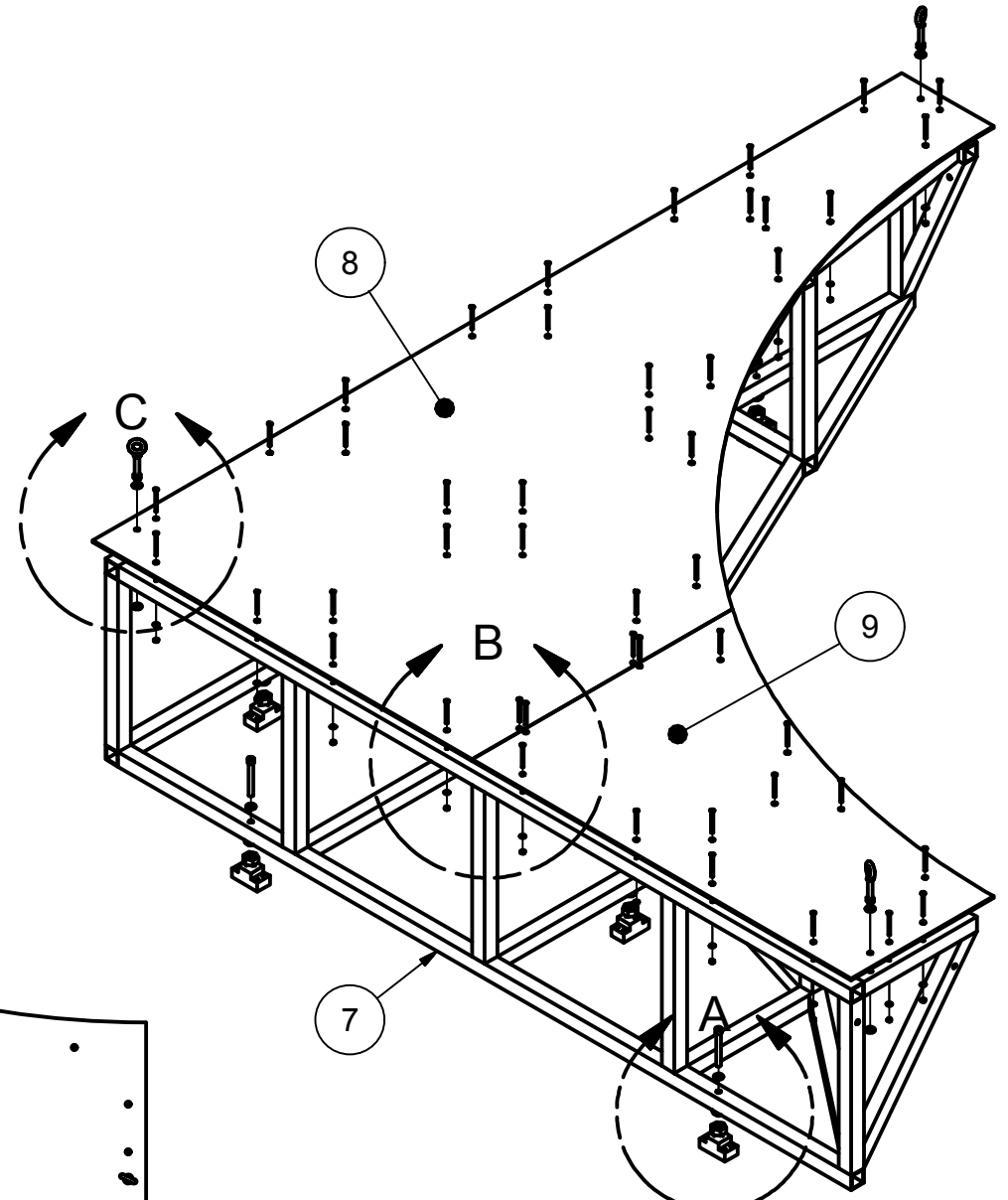
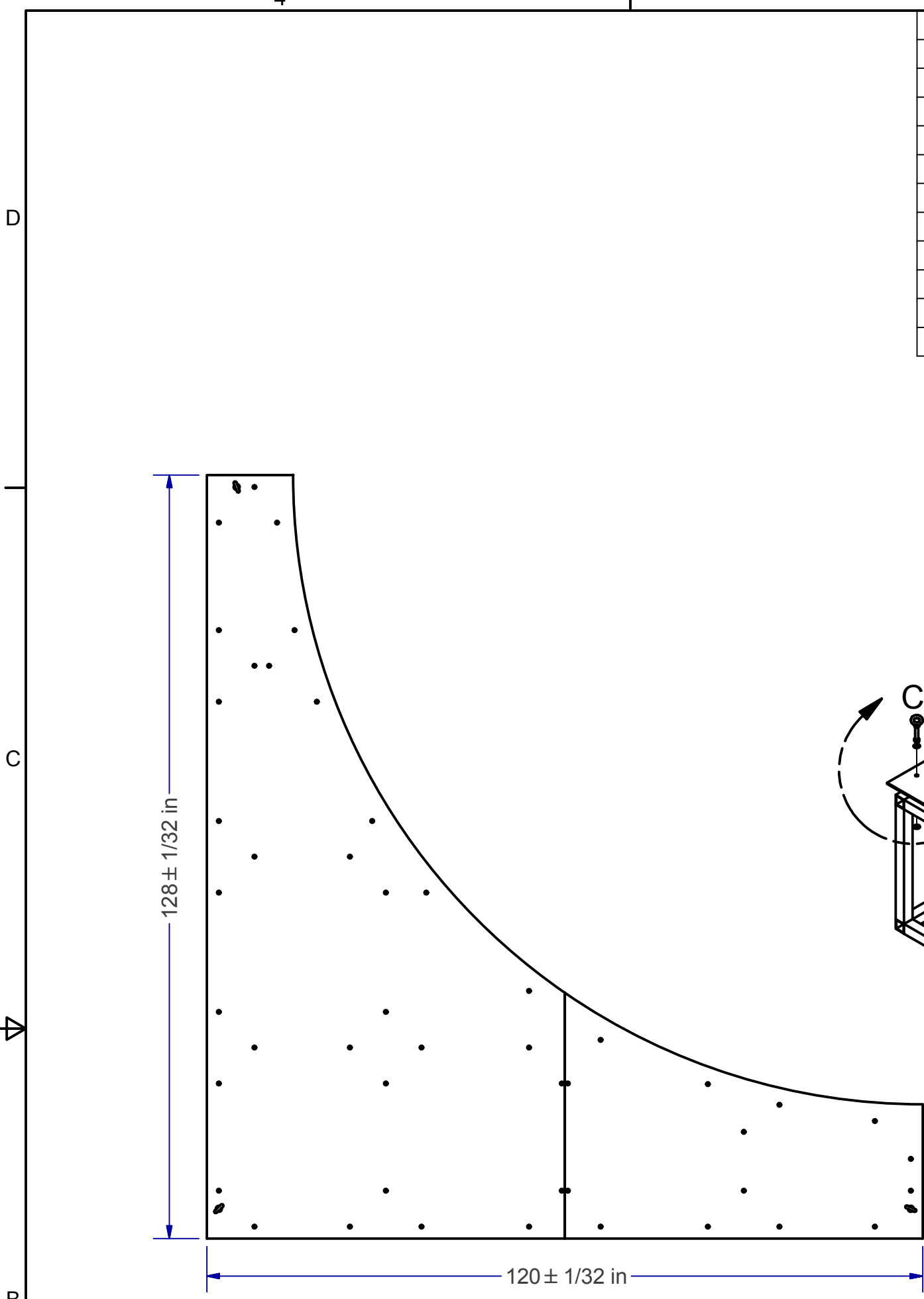

QS-01

GENERAL TOLERANCES		DRAWN	OLD DOMINION UNIVERSITY	
DECIMAL	ANGULAR	JASON MOORE	LANGLEY FULL SCALE TUNNEL	
X.X" ± 0.5"	XX' ± 1'	ENG. APPROVED BY	TITLE	
X.XX" ± 0.05"	XX.X' ± 0.1'	DREW LANDMAN	QUARTER SURROUND 1	
X.XXX" ± 0.005"	WELDMENTS	LAST UPDATED BY	SIZE	DWG NO
X.XXXX" ± 0.0005"	± 1/16"	JASON MOORE	C	QS-01
			SCALE	REV
			3:64	
			SHEET 1 OF 2	

PRODUCED BY AN AUTODESK EDUCATIONAL PRODUCT

PRODUCED BY AN AUTODESK EDUCATIONAL PRODUCT